

409753. ULN 2003L

**USMikroChips**

**ULN 2003A&L/2803A High-Voltage, High-Current Darlington Arrays**

**General Description**

The Series ULN2003 and the ULN2803 are High-Voltage, High-Current Darlington Arrays that are comprised of silicon NPN Darlington pairs on a common monolithic substrate (The 2003 has seven Darlington pairs and the 2803 has eight Darlington pairs). All units have open-collector outputs and integral diodes for inductive load transient suppression

The Series 2003 and 2803 have a 2.7k  $\Omega$  series base resistor for each Darlington pair, allowing operation directly with TTL or CMOS Operating at a voltage of 5 V. These devices will handle numerous interface needs, particularly those beyond the capabilities of standard logic buffers. These devices will sink a minimum of 350 mA when driven from a "totem pole" logic output. Peak inrush current of 600 mA are permissible, making them ideal for driving tungsten filament lamps. The output transistors are capable of sinking 500 mA and will sustain at least 50 V in the OFF state.

**2003/2803 SERIES TABLE 1**

PART #	FUNCTION	PACKAGE*
ULN2003A	7 CHANNEL	16 PIN DIP
ULN2003L	7 CHANNEL	16 PIN SOIC
ULN2803A	8 CHANNEL	18 PIN DIP

\*PACKAGE CONFORMS TO JEDEC STANDARDS

**Absolute Maximum Ratings**

- Output Voltage,  $V_{CE}$ .....50V
- Input Voltage,  $V_{IN}$ .....30V
- Continuous Collector Current,  $I_C$ .....500mA
- Continuous Input Current,  $I_{IN}$ .....25mA
- Power Dissipation,  $P_D$ .....
  - (One Darlington Pair).....1.0W
  - (Total Package).....2.0W\*
- Operating Temperature Range,  $T_A$ .....
  - 20°C to +85°C
- Storage Temperature Range,  $T_S$ .....
  - 55°C to +150°C

\* Derate at a rate of 16.67mW/C above +25°C in DIP package under normal operating conditions, these devices will sustain 350mA per output with  $V_{CE(SAT)} = 1.6V$  at +70°C with a pulse width of 20ms and a duty cycle of 34%

**Functional Diagram**

**2003**

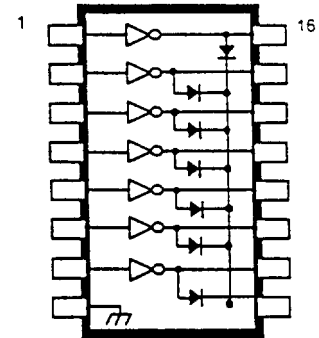

**2803**

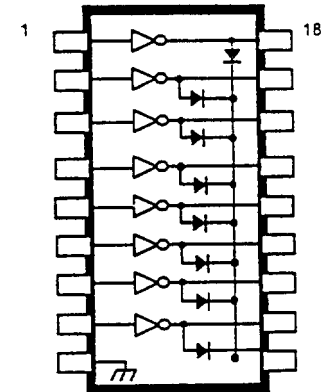

**Allowable Average Power Dissipation As A Function Of Ambient Temperature**

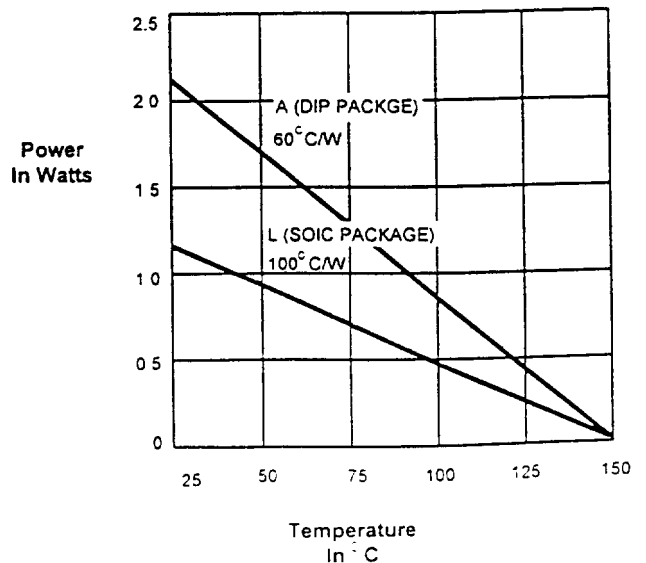

# ELECTRICAL CHARACTERISTICS @ 25°C\*

\*Unless Otherwise Noted

Characteristics	Symbol	Test Fig.	Test Conditions	Limits			Units
				Min	Typ	Max	
Output Leakage Current	ICEX	1	VCE = 50V, TA = 25°C	-	-	50	μA
			VCE = 50V, TA = 70°C	-	-	100	μA
Collector-Emitter Saturation Voltage	VCE(SAT)	2	IC = 100mA, IB = 250μA	-	0.9	1.1	V
			IC = 200mA, IB = 350μA	-	1.1	1.3	V
			IC = 350mA, IB = 500μA	-	1.3	1.6	V
Input Current	IIN(ON)	3	VIN = 3.85V	-	9.3	13.5	mA
			IIN(OFF)	4	IC = 500μA, TA = 70°C	50	65
Input Voltage	VIN(ON)	5	VCE = 2.0V, IC = 200mA	-	-	2.4	V
			VCE = 2.0V, IC = 250mA	-	-	2.7	V
			VCE = 2.0V, IC = 300mA	-	-	3.0	V
Input Capacitance	CIN	-		-	15	25	pF
Turn-On Delay	tPLH	-	0.5EIN to 0.5EOUT	-	0.25	1.0	μS
Turn-Off Delay	tPHL	-	0.5EIN to 0.5EOUT	-	0.25	1.0	μS
Clamp Diode Leakage Current	IR	6	VR = 50V, TA = 25°C	-	-	50	μA
			VR = 50V, TA = 70°C	-	-	100	μA
Clamp Diode Forward Voltage	VF	7	IF = 350mA	-	1.7	2.0	V

## Partial Schematic\*

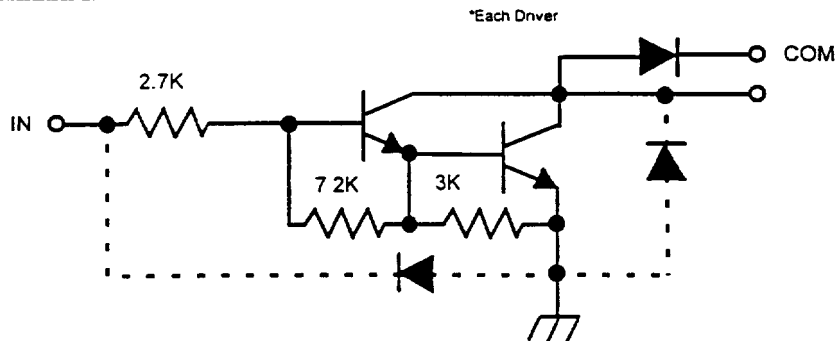

## Test Figures

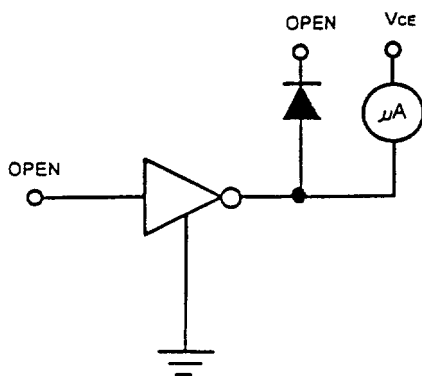

FIGURE 1

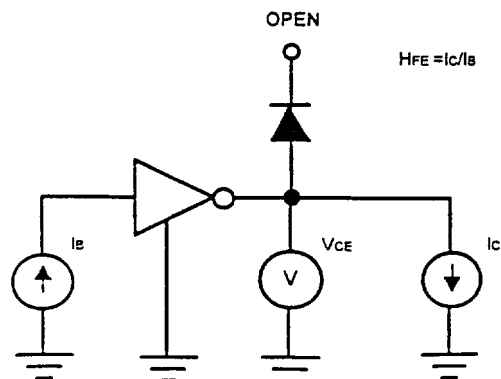

FIGURE 2

# Test Figures

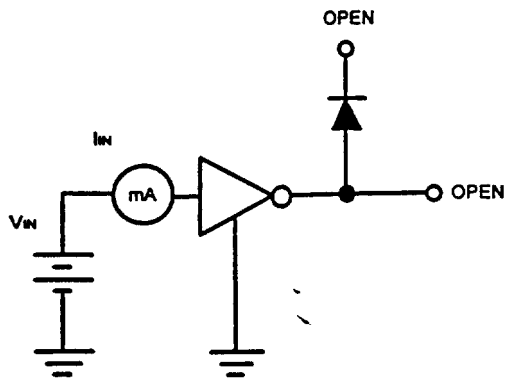

FIGURE 3

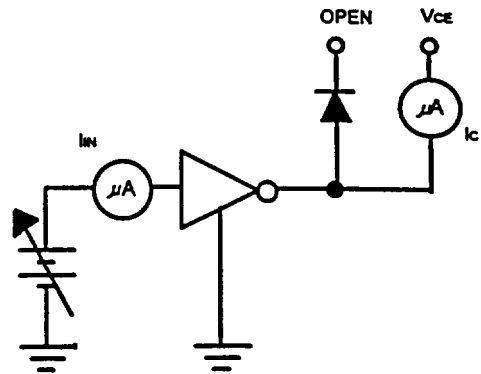

FIGURE 4

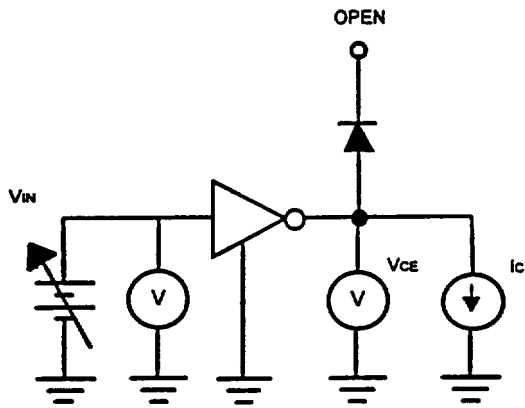

FIGURE 5

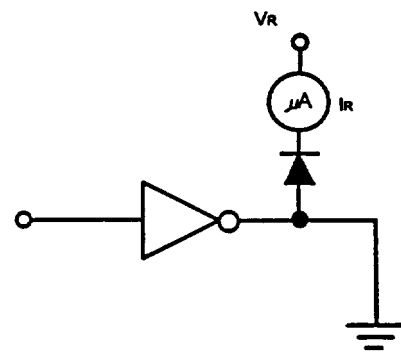

FIGURE 6

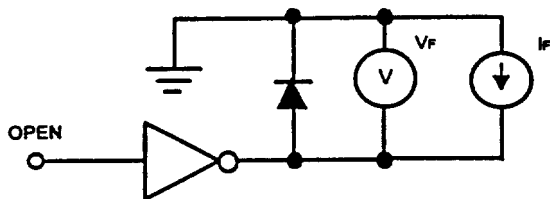
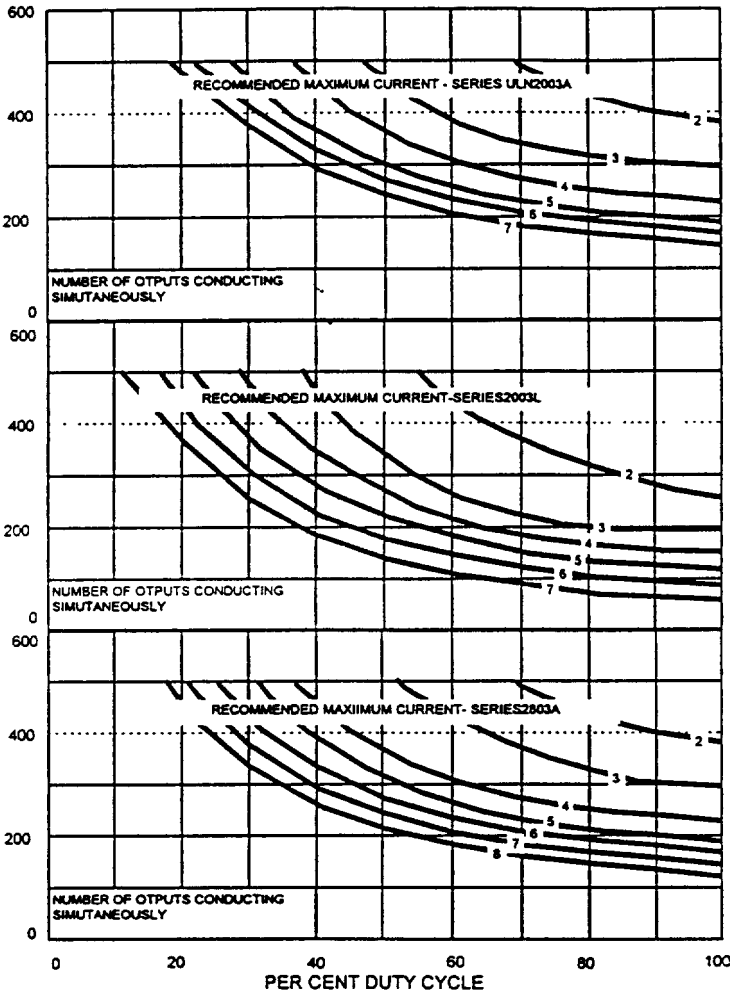
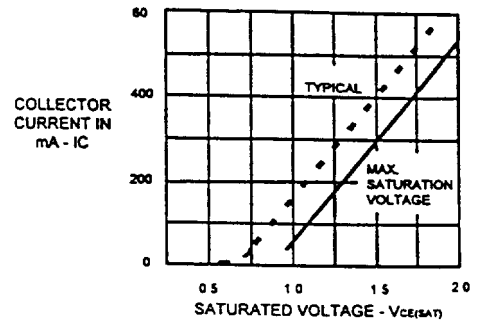

FIGURE 7

**PEAK COLLECTOR CURRENT AS A FUNCTION OF DUTYCYCLE**



**COLLECTOR CURRENT AS A FUNCTION OF SATURATED VOLTAGE**



**PEAK COLLECTOR CURRENT IN Ma @ -70°C**

**COLLECTOR CURRENT AS A FUNCTION OF INPUT CURRENT**

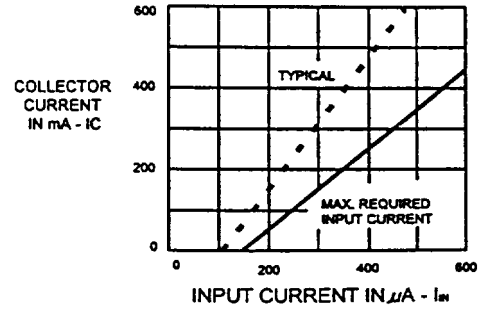

**INPUT CURRENT AS A FUNCTION OF INPUT VOLTAGE**

